

COMPLEMENTOS DEL AIRE  
POMPA PER VUOTO A SECCO  
DRY VACUUM PUMP

40 S



Gruppo pompante in ghisa, accoppiato direttamente al motore, su base e carter in ABS. Filtro in aspirazione e valvola silenziatrice in mandata.



Cast-iron pumping unit, coupled directly to the motor, on a base and with a case made of ABS. Filter on the suction side and silencing valve on the delivery side.



SPECIFICHE - SPECIFICATIONS

			50 Hz	60 Hz
Portata	Pumping speed	(Nm <sup>3</sup> /h)	45	54
Vuoto finale (Ass.)	Ult.vacuum (Abs)	(mbar)	150	150
Pressione finale rel.	Pressure	(Bar)	0.8	0.95
Esecuzione motore	Motor version	(V) multi tensione – multivolts	Y	380-400-415-440-460-480
		(V) 1 ~ - single phase	Δ	220-230-240-254-275
Potenza motore	Motor rating	(Kw) multi tensione – multivolts	1.3	1.3
		(Kw) 1 ~ - single phase	1.7	1.7
Nr.giri	Motor speed	giri/min - rpm	1450	1750
Rumorosità media	Noise level	(dB)	70	70
Peso max.	Max.weight	(Kg)	50	50

Salvo modifiche tecniche - We reserve the right to alter technical information.

## COMPLEMENTOS DEL AIRE

### DIMENSIONI - DIMENSIONS

(mm)	
A	495
B	325
C	330
D	140
E	200
G	85
K	100
M	205
P	112
Q	255
Øa	1"G

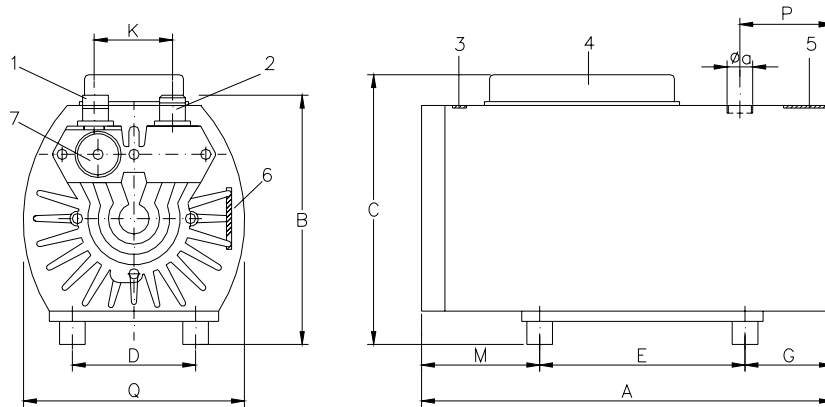

Salvo modifiche tecniche - We reserve the right to alter technical information.

1	Valvola di aspirazione	Suction valve	5	Targhetta dati	Data plate
2	Valvola silenziatrice	Silente valve	6	Targhetta dati	Data plate
3	Freccia senso di marcia	Rotation arrow	7	Porta filtro	Filter ring
4	Morsettiera	Wiring box			

### PRESTAZIONI - PERFORMANCE CURVE

